

# VH-AU



VH-810-AU with M15s NC controller (Opt.)

## HYDRAULIC BOX & PAN BRAKE - AU

### STANDARD ACCESSORIES

- 1 Maximum 80 mm clamping stroke
- 2 Higher segmented finger tools
- 3 Adjustable table crowning design
- 4 Bending angle adjustment setup
- 5 3 functions foot pedal (Clamp / Unclamp / Bend)

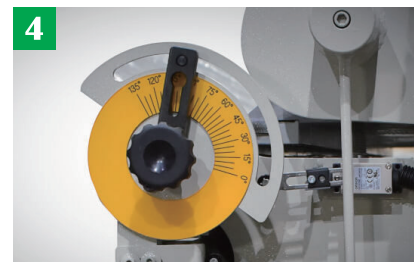
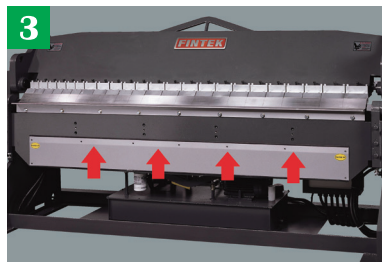

### OPTIONAL ACCESSORIES

- A 800mm/1250mm NC power back gauge with digital display unit and platform.
- B 2 axes NC Controller included:
  1. Motorized back gauge 800mm
  2. Bending Angle setting.
  3. Programmable functions
- C CE conformity.

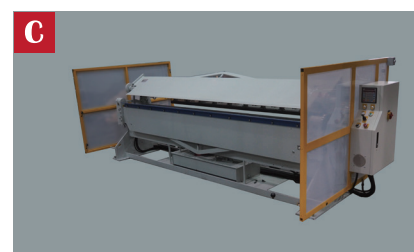



VH-810-AU with Side Guard (Opt.)

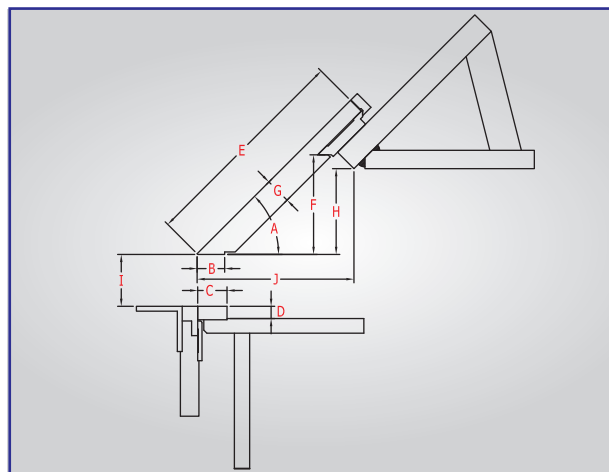

Dimensions

A	45 degrees	F	160 mm
B	45 mm	G	42 mm
C	48 mm	H	140 mm
D	20 mm	I	80 mm
E	355 mm	J	257 mm

## SPECIFICATION

MODEL	VH-610-AU	VH-810-AU	VH-1010-AU
Bending Length	2050 mm / 80"	2550 mm / 100"	3050 mm / 122"
Bending Capacity	Mild Steel	3.5 mm / 10GA	3.5 mm / 10GA
	Stainless Steel	2.0 mm / 14GA	2.0 mm / 14GA
Bending Angle	0-135°	0-135°	0-135°
Max open height of top beam	80 mm	80 mm	80 mm
Bending Adjustment	25 mm / 1"	25 mm / 1"	25 mm / 1"
Min Reverse Bend	25 mm / 1"	25 mm / 1"	25 mm / 1"
Motor	5 HP	5 HP	5 HP
Packing size (mm)	2870 x 1470 x 1750	3570 x 1470 x 1750	4170 x 1470 x 1750
Packing weight	2470 kgs	3070 kgs	3665 kgs

• All specifications & design are subject to change without prior notice.

## Top Clamping Tools quantity

Model	VH-6-AU	VH-8-AU	VH-10-AU
75 mm	6	6	6
100 mm	3	4	5
125 mm	8	10	10
150 mm	2	3	6
Total quantity	19	23	27
Total Length	2050 mm / 80"	2550 mm / 100"	3100 mm / 122"

